

pointek

ULS 200

MILLTRONICS

Safety Guidelines

Warning notices must be observed to ensure personal safety as well as that of others, and to protect the product and the connected equipment. These warning notices are accompanied by a clarification of the level of caution to be observed.

Qualified Personnel

This device/system may only be set up and operated in conjunction with this manual. Qualified personnel are only authorized to install and operate this equipment in accordance with established safety practices and standards.

Warning: This product can only function properly and safely if it is correctly transported, stored, installed, set up, operated, and maintained.

Note: Always use product in accordance with specifications.

Copyright Siemens Milltronics Process Instruments Inc. 2003. All Rights Reserved

Disclaimer of Liability

This document is available in bound version and in electronic version. We encourage users to purchase authorized bound manuals, or to view electronic versions as designed and authored by Siemens Milltronics Process Instruments Inc. Siemens Milltronics Process Instruments Inc. will not be responsible for the contents of partial or whole reproductions of either bound or electronic versions.

While we have verified the contents of this manual for agreement with the instrumentation described, variations remain possible. Thus we cannot guarantee full agreement. The contents of this manual are regularly reviewed and corrections are included in subsequent editions. We welcome all suggestions for improvement.

Technical data subject to change.

MILLTRONICS® is a registered trademark of Siemens Milltronics Process Instruments Inc.

Contact SMPI Technical Publications at the following address:

Technical Publications
Siemens Milltronics Process Instruments Inc.
1954 Technology Drive, P.O. Box 4225
Peterborough, Ontario, Canada, K9J 7B1
Email: techpubs@siemens-milltronics.com

For the library of SMPI instruction manuals, visit our Web site: www.siemens-milltronics.com

Table of Contents

Pointek ULS 200	2
Specifications	3
Installation	5
Location	5
Mounting and Dimensions	6
Threaded	6
Sanitary	7
Interface	9
Interconnection	10
Operation	11
Start Up	11
Quick Start	11
Display / Operation Status	13
Applications	14
Adjustments	20
Troubleshooting	28
Maintenance	29
Certifications	30

Pointek ULS 200

Note: Pointek ULS 200 is to be used only in the manner outlined in this instruction manual.

Pointek ULS 200 is an ultrasonic based process level switch providing high or low switch action on liquids or solids. The process part (sensor) is Tefzel® or Kynar Flex®, allowing it to be used in a wide variety of industries.

Pointek ULS 200 contains an ultrasonic transducer and temperature sensing element. The transducer emits a series of ultrasonic pulses. Each pulse is reflected as an echo from the material and sensed by the transducer. Pointek ULS 200 processes the echo using Milltronic's proven Sonic Intelligence® techniques. Filtering is applied to help discriminate between the true echo from the material and the false echoes from acoustical and electrical noises and agitator blades in motion. The time for the pulse to travel to the material and back is temperature compensated and then converted into distance for display and relay actuation.

The Pointek ULS 200 is an excellent primary detection device, but should not be used as a backup device. For backup devices use a contacting technology such as the Pointek CLS 200. The optional sanitary version affords quick removal and ease of cleaning as demanded by the food, beverage, and pharmaceutical industries.

Pointek ULS 200 Outputs

- switch outputs programmable for high-high, high, low, and low-low level actions
- fail-safe programmable

Pointek ULS 200 Features

- 2" NPT, 2" BSP or PF2 or 4" 3A approved Tri-clamp process connection
- 2 conduit connections, 1/2" NPT or PG 13.5
- non-corrosive enclosure and wetted parts
- 2 button programming
- level run/program LCD display

Pointek ULS 200 Applications

- liquids, slurries, and fluid materials
- foods and pharmaceuticals
- chemicals

Specifications

ac Version

Power

- 100 - 230 V ac, $\pm 15\%$, 50/60 Hz, 12 VA (5W) max.

Fuse

- Slow-Blow, 0.25 A, 250 V ac

Output:

- repeatability: 0.25 % of full range
- resolution: 3 mm (0.1")
- relay: 2 form C (SPDT) contacts, rated 5A at 250 V ac, non-inductive

dc Version

Power

- 18 to 30 V dc, 3 W

Output:

- repeatability: 0.25 % of full range
- resolution: 3mm (0.1")
- relay: 2 form C (SPDT) contacts, rated 5 A at 48 V DC
OR
- transistor: 2 transistor switches, rated 100 mA maximum at 48 V DC

Environmental

- location: indoor/outdoor
- altitude: 2000m max
- ambient temperature: - 40° to 60° C (- 40° to 140° F)
* - 20° C (-5° F) if metal mounting
- relative humidity: suitable for outdoor (Type 6 / NEMA 6 / IP67 enclosure)
- installation category: II
- pollution degree: 4

Process Pressure:

- vented to atmosphere

Switching Range

- liquids: 0.25 to 5m (0.8 to 16.4 ft)
- solids: 0.25 to 3m (0.8 to 9.8 ft)

Memory

- non-volatile EEPROM

Programming

- 2 keys

Temperature Compensation

- built-in to compensate over the operating range

Display

- liquid crystal
- three 9mm (0.35") digits for reading of distance between sensor face and material, multi-segment graphic for operation status

Electronics/Enclosure

- termination: terminal block, 2.5mm² (14 ga) solid 1.5 mm² (16 ga) stranded, maximum
- material: plastic
OR
epoxy coated aluminum with gasket
- ingress protection: Type 6 / NEMA 6 / IP67¹
- conduit: aluminum, 2 connections } 1/2" NPT
plastic, 2 connections } PG 13.5

Sensor

- material: Tefzel²® or Kynar Flex³®
- mounting: threaded:
 - 2" NPT, 2" BSP or PF2
 - optional flange adapter, to 3" ANSI, DIN 65PN10, and JIS 10K3Bsanitary:
 - 4" 3A compliant Tri-clamp fitting

Approvals

- CE (EMC performance available upon request.), CSA^{NRTL/C}, FM, 3A
 - CSA/FM Class 1, Division 1, Group A, B, C, D; Class II, Group E, F, G; Class III
 - Europe: ATEX II 2G, EEx md IIC T5
- (see product nameplate for approval details)

1. Use only approved, suitable size hubs for watertight applications.
2. Tefzel[®] is a registered trademark of Dupont.
3. Kynar Flex[®] is a registered trademark of Elf Atochem North America.

Installation

The Pointek ULS 200 should be mounted in an area within the temperature range specified and suitable to the housing rating and materials of construction. Make sure the cover is accessible to allow programming, wiring, and access to the display.

Keep the Pointek ULS 200 away from high voltage or current runs, contactors, and SCR control drives.

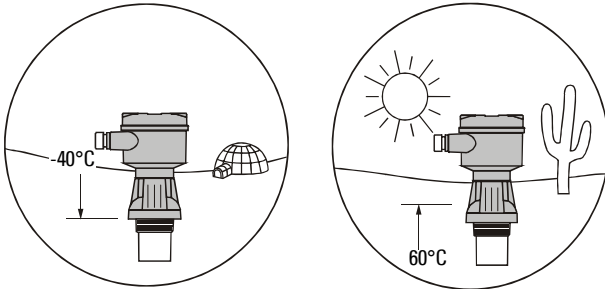

Warning: Explosion Hazard. Substitution of components may impair suitability for Class 1, Division 2 applications.

Location

Locate the Pointek ULS 200 so that it has a clear sound path perpendicular to the material surface.

The Pointek ULS 200 sound path should not intersect the fill path, rough walls, seams, rungs, or any other obstruction.

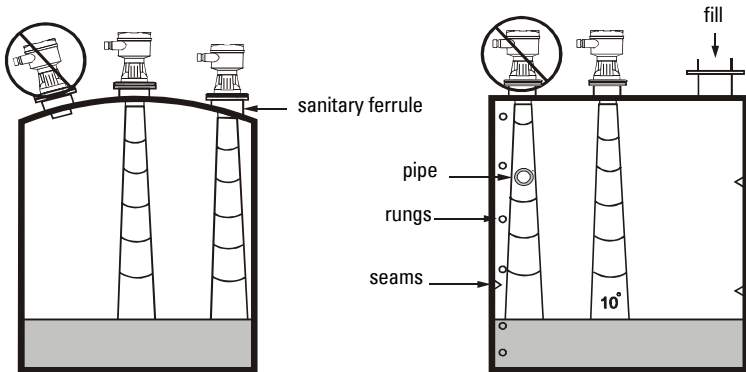

Mounting and Dimensions

Mount the ULS 200 with sensor face at least 25cm above the highest anticipated level.

Threaded

The Pointek ULS 200 is available in three thread types: 2" NPT, 2" BSP, or PF2.

Before mounting the Pointek ULS 200, ensure that the mating threads are of the same type, otherwise the threads can be damaged.

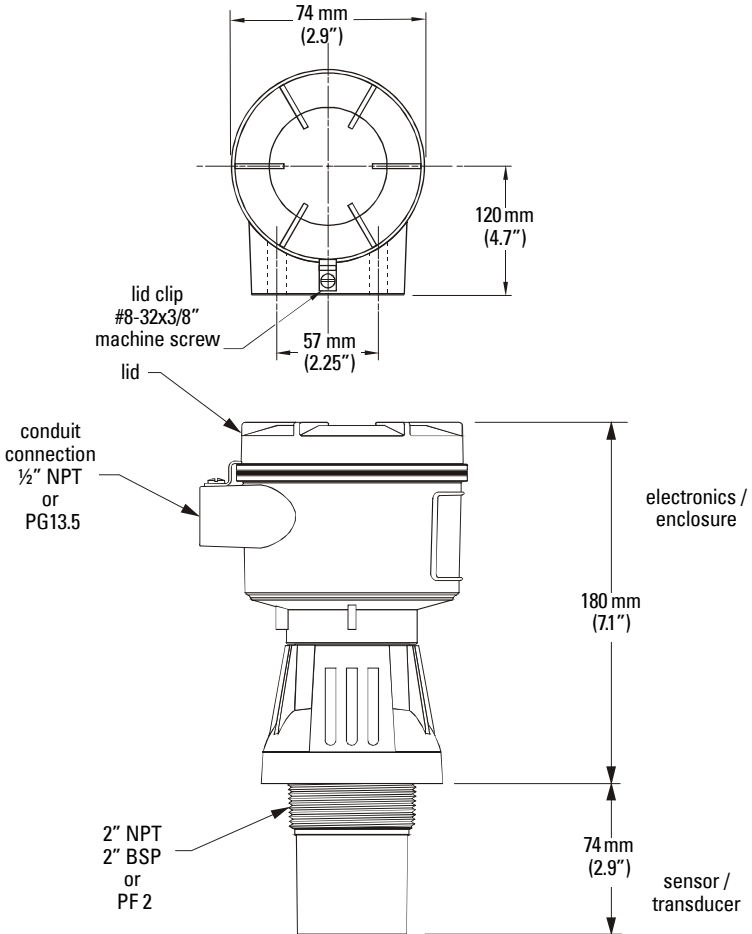

Notes:

- Dimensions are nominal and may vary with material types.
- Non-metallic enclosure does not provide grounding between connections.
- Use grounding type bushings and jumpers.

The Pointek ULS 200 can be fitted with the optional 75 mm (3") flange adapter for mating to 3" ANSI, DIN 65PN10 and JIS 10K 3B flanges.

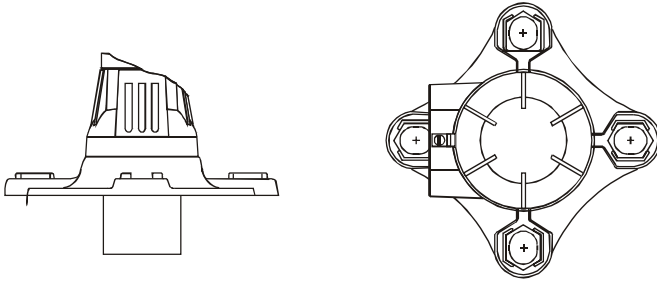

Note: For CSA/FM approved Hazardous Location Models, see Siemens Milltronics drawing 0-9440026Z-DI-A.

Sanitary

The Pointek ULS 200 also comes in a sanitary version for use in the food and pharmaceutical industries.

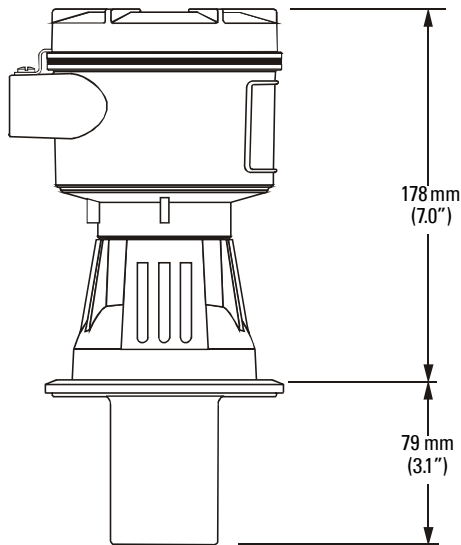

Notes:

- Dimensions are nominal and may vary with material types.
- Refer to threaded for other dimensions.

Mount the Pointek ULS 200 onto the top of the tank's sanitary ferrule.

Secure mating by surrounding the joint with the optional clamp.

Tighten the adjusting nut with your hand. Do not use a wrench.

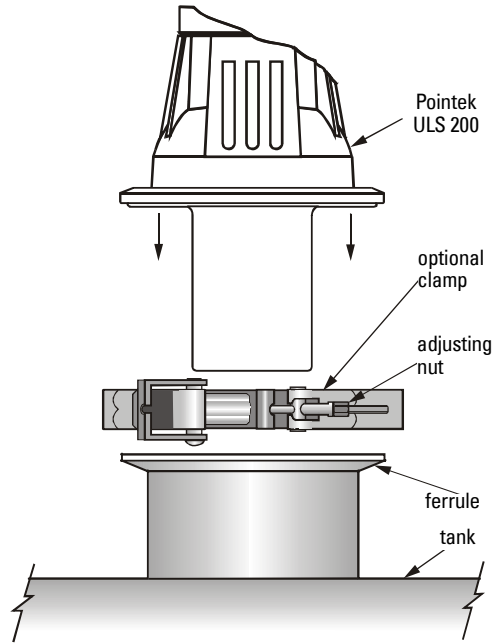

Sanitary Ferrule, 4" FDA Approved
(U.S. Food and Drug Administration)

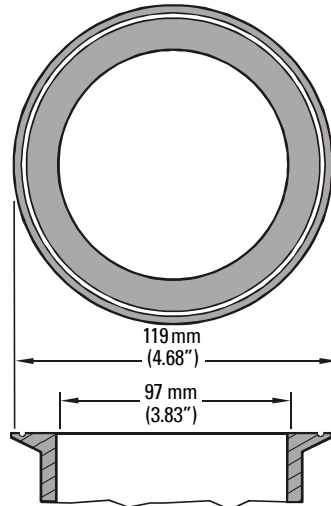

*dimensions are approximate

Interface

ac Version

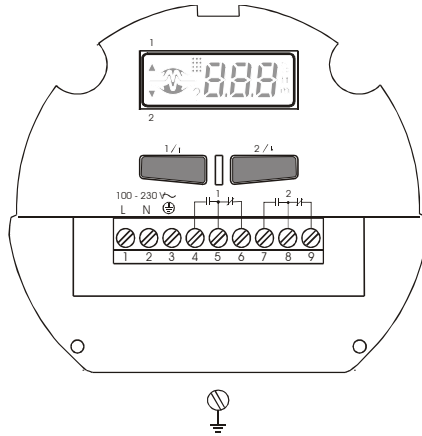

Notes:

- A circuit breaker or switch in the building installation, marked as the disconnect switch, shall be in close proximity to the equipment and within easy reach of the operator.
- Relay contact terminals are for use with equipment having no accessible live parts and wiring having insulation suitable for at least 250 V.

dc Version - Relay Output

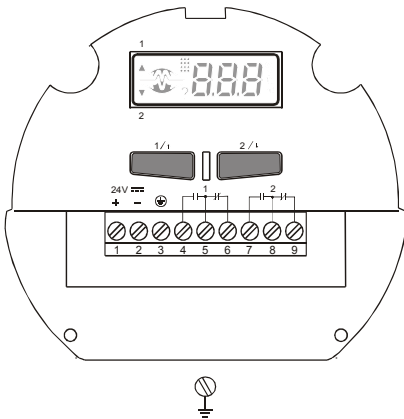

dc Version - Transistor Output

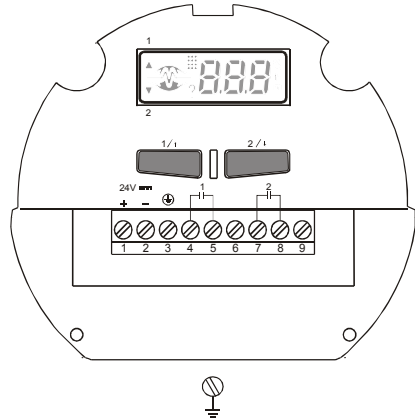

Note: dc terminals shall be supplied from an SELV source in accordance with IEC 1010-1 Annex H.

Interconnection

Notes:

- Installation shall only be performed by qualified personnel and in accordance with local governing regulations.
- This product is susceptible to electrostatic shock. Follow proper grounding procedures.

Separate cables and conduits may be required to conform to standard instrumentation wiring or electrical codes.

Relay Output

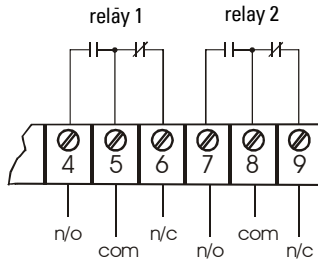

All relays are shown in their de-energized (unpowered) state.

Optional Transistor Output – dc Version only

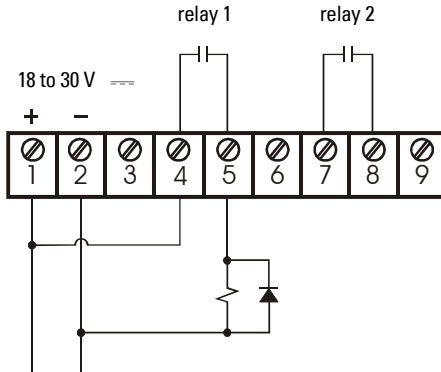

Power

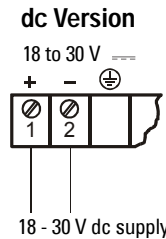
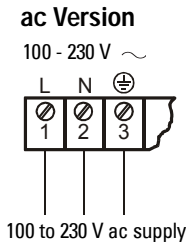

Operation

Start Up

With the Pointek ULS 200 correctly installed (or aimed at a wall 0.25 to 5 m away), apply power and observe the Pointek ULS 200 start up sequence. The unit will cycle through the following screens:

1. Lighting of all possible LED values
2. Product revision number
3. Product model number
4. Run mode

The display and operation sequence arrives within a few seconds at the run mode, which is the measurement of the distance from the transducer face to the material level in the units indicated. Full instructions on setting up the unit are found at Applications on page 13 and Adjustments on page 19.

Quick Start

Use this setup method if you have a basic high/low application and you are setting up the unit in a place where you can easily adjust the measured distance.

The Pointek ULS 200 relays are preset as: relay 1 = alarm 1, high alarm at 0.25 m

relay 2 = alarm 2, low alarm at 5.00 m

To change the setpoints by reference method, set the material or target to the distance as displayed. Press the `1 / ↑` or `2 / ↓` key. The display responds by displaying the current setpoint function and value. By pressing the alarm key a second time, the Pointek ULS 200 changes the setpoint to the value currently being measured.

After viewing or changing the setpoint, the Pointek ULS 200 reverts to the run mode.

relay 1

1. Position the unit so that it reads 0.75 m.
- 2.

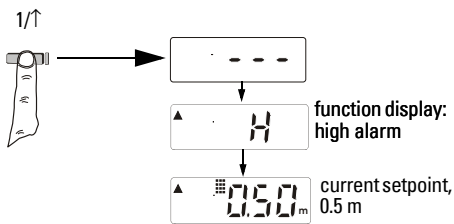

- 3.

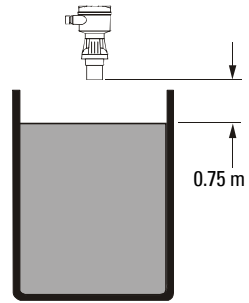
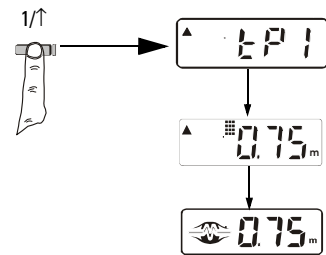

4. Once installed, the unit will register a high alarm at 0.75 m from the sensor face.

Loss of Echo
if LOE retry

relay 2

1. Position the unit so that it reads 3.50 m.
- 2.

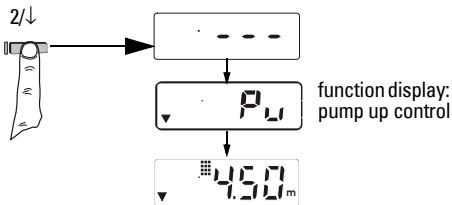

- 3.

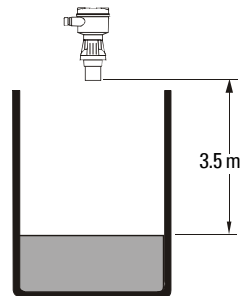
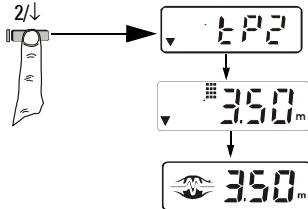

4. Once installed, the unit will register a low alarm at 3.50 m from the sensor face.

Loss of Echo
if LOE retry

Display / Operation Status

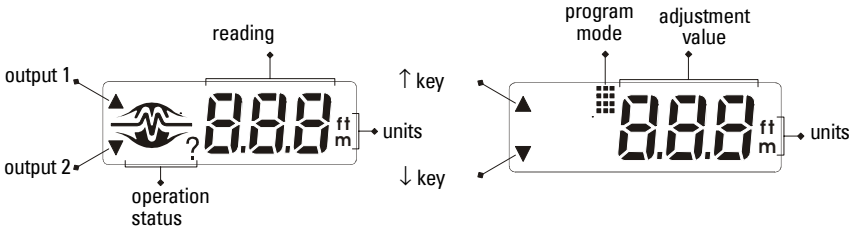

Operation Status - Run Mode



- echoes are valid and within range.



-echoes are lost due to poor conditions or out of range.
This may be typical in applications where there are deep vessels and the material level is normally out of range.
Refer to Troubleshooting.



-extended loss of echo period. Operation has gone into fail-safe.
Refer to Troubleshooting.

Applications

Pointek ULS 200 is designed for use as a process level switch. The local display is used only as an aid during start up. The instrumentation interface is comprised solely of the two relay outputs. Switching applications are based on the relay functions adjustment.

The outputs can be set to function in the desired mode.

Application	Function	Relay 1	Relay 2
High / Low level switch	*1	High Alarm	Low Alarm
High level switch with two height alarms	2	High Alarm	High Alarm
Low level switch with two height alarms	3	Low Alarm	Low Alarm
High level switch with loss of echo alarm	4	High Alarm	LOE Alarm
Low level switch with loss of echo alarm	5	Low Alarm	LOE Alarm
Pump down control with low level alarm	6	Pump Down	Low Alarm
Pump down control with high level alarm	7	Pump Down	High Alarm
Pump up control with low level alarm	8	Pump Up	Low Alarm
Pump up control with high level alarm	9	Pump Up	High Alarm
Pump down control with loss of echo alarm	10	Pump Down	LOE Alarm
Pump up control with loss of echo alarm	11	Pump Up	LOE Alarm
Pump up control and Pump down control	12	Pump Down	Pump Up
Dual pump down control	13	Pump Down	Pump Down
Dual pump up control	14	Pump Up	Pump Up

* Factory setting

Alarm: the relay de-energizes to set the alarm 'ON'

Control or Pump: the relay energizes to set the device 'ON'

High Level Alarm Switch

This application uses Pointek ULS 200 to provide an alarm output, high and/or high-high alarm, when the process material rises to a high level. The device range applies to its switching capability, and not the process range of the material.

It is therefore common to apply the switch on vessels where the material is normally below the unit's range. Under such a condition the Pointek ULS 200 loses echo, and if prolonged, defaults to fail-safe operation. As this would be a normal occurrence, it is not advisable to select the fail-safe high option.

If the high level switch is being applied to a vessel within the 3 / 5 m range, a loss of echo and ensuing fail-safe condition would not be a common occurrence. The fail-safe default would then be at the user's discretion.

Application Adjustments

alarm function 2 - high / high-high alarm
4 - high / Loss of Echo (LOE)

alarm setpoint set the high and / or high-high alarms to the desired values

fail-safe mode 1 - high, except if the process range is beyond the Pointek ULS 200 operating range (3 / 5 metres)
2 - low
3 - hold

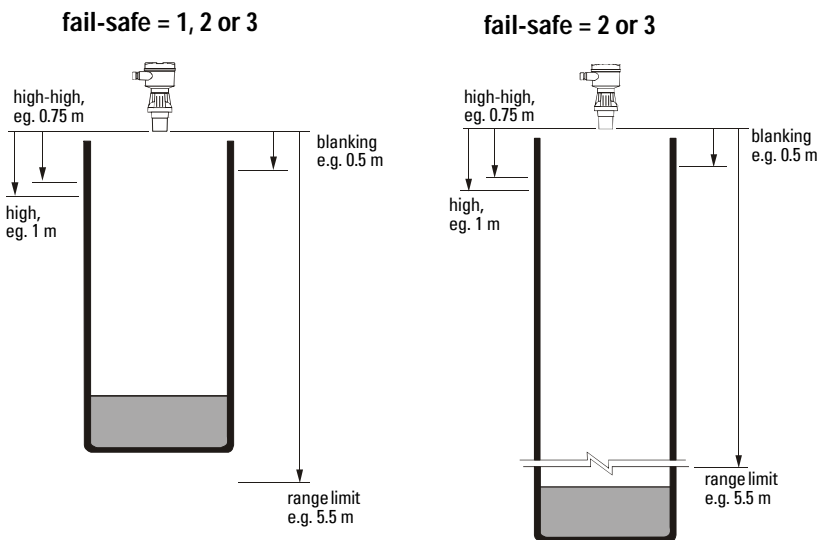

High / Low Level Alarm Switch

This application uses Pointek ULS 200 to provide high and low level alarms. The device range applies to its switching capability, and not the process range of the material. As such the low and/or low-low level setpoints must be within the device's range (3 / 5 metres).

If the material can fall below the unit's range, the Pointek ULS 200 loses the echo, and if prolonged, defaults to fail-safe operation. The fail-safe default should be set to suit the application.

Application Adjustments

alarm function 1 - high / low alarm

alarm setpoint set the high and/or low alarms to the desired values

fail-safe mode 1 - high
2 - low
3 - hold

fail-safe = 1, 2 or 3

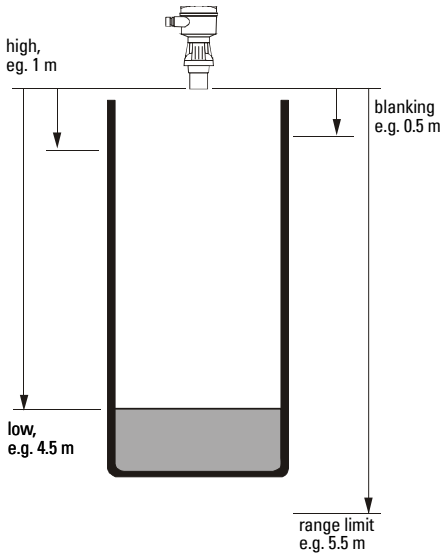

fail-safe = 2 or 3

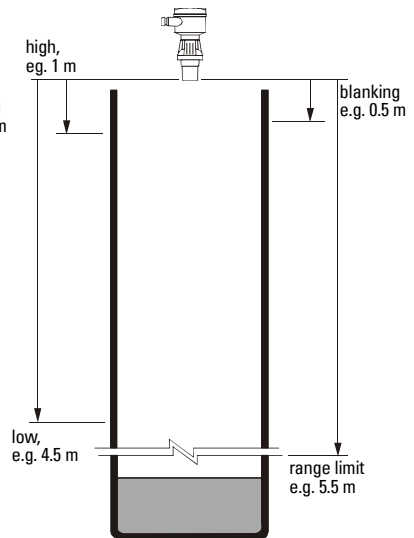

Low Level Alarm Switch

This application uses the Pointek ULS 200 to provide one or two low level alarms. The device range applies to its switching capability, and not the process range of the material. As such the low and / or low-low level setpoints must be within the device's range (3 / 5 metres).

If the material can fall below the unit's range, the Pointek ULS 200 loses the echo, and if prolonged, defaults to fail-safe operation. The fail-safe default should be set to suit the application.

Application Adjustments

alarm function 3 - low / low-low alarm

5 - low / LOE alarm

alarm setpoint set the low and / or low-low alarms to the desired values

fail-safe mode 1 - high

2 - low

3 - hold

fail-safe = 1, 2 or 3

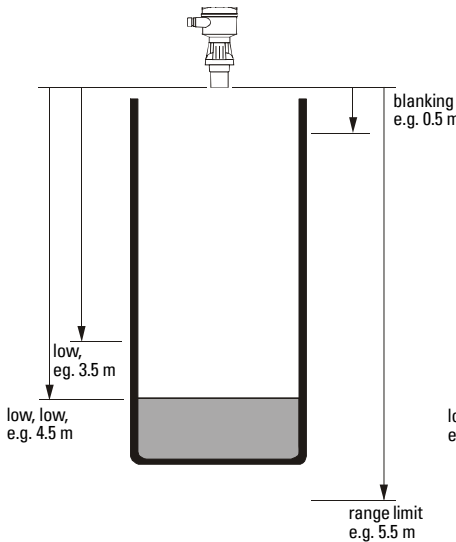

fail-safe = 2 or 3

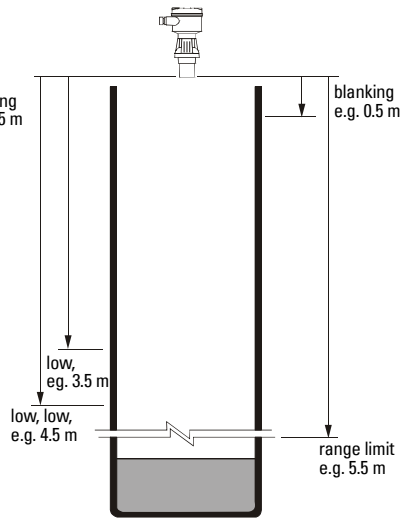

Dual Pump Control

This application uses Pointek ULS 200 to provide a control output when the process material rises to a high level. The device range applies to its switching capabilities, and not to the process range of the material. As such, the level setpoints must be within the device's range (3 / 5metres).

Typically, wet wells are used to temporarily hold storm and/or waste water. When the water surface reaches a high level setpoint, the wet well is pumped down. The process material will be pumped down by the deadband value to another setpoint where the control will turn off.

Application Adjustments

- relay function 6 - high control / low alarm
- 7 - high control / high alarm
- 10 - high control / LOE alarm
- 13 - high control / high control

relay setpoints: set to desired values

deadband values: referenced from relay setpoints
(distance from Pump Start setpoint to Pump Stop setpoint)

Relay Function 13: Dual Pump Down

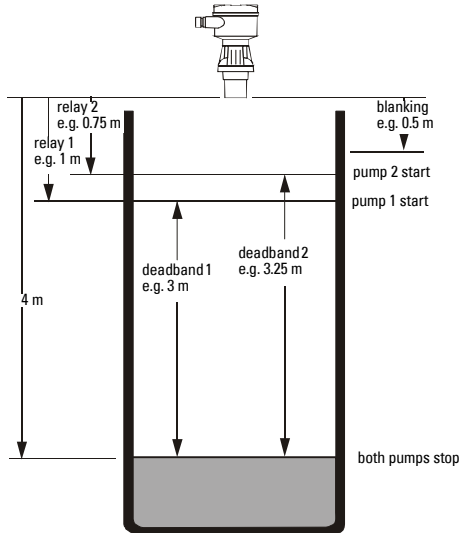

Pump Control with Level Alarm

This application uses the Pointek ULS 200 to provide pump control and one level alarm. The device range applies to its switching capability, and not the process range of the material. As such the low level setpoints must be within the device's range (3 / 5 metres).

If the material reaches a control setpoint, the well is pumped down or up respectively. If the material reaches an alarm setpoint, the alarm will sound until the material moves beyond the deadband value.

Application Adjustments

- relay function 6 - high control / low alarm
- 7 - high control / high alarm
- 8 - low control / low alarm
- 9 - low control / high alarm
- 10 - high control / LOE alarm
- 11 - low control / LOE alarm

alarm setpoint set the low alarm to the desired values

Relay Function 8: Pump Up Control with Low Alarm

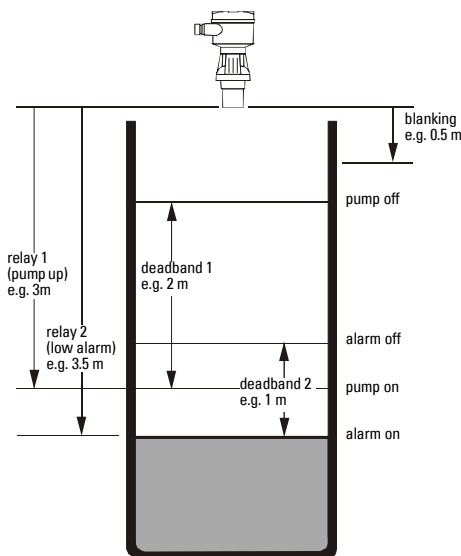

Adjustments

There are several operating adjustments that can be made to the Pointek ULS 200.

To access the operating adjustments, simultaneously press both keys repeatedly until the desired adjustment is obtained. A viewing period of the adjustment value is initiated. During this time the value can be changed by pressing either the 'up' or 'down' key. After viewing or changing, operation automatically reverts to the run mode.

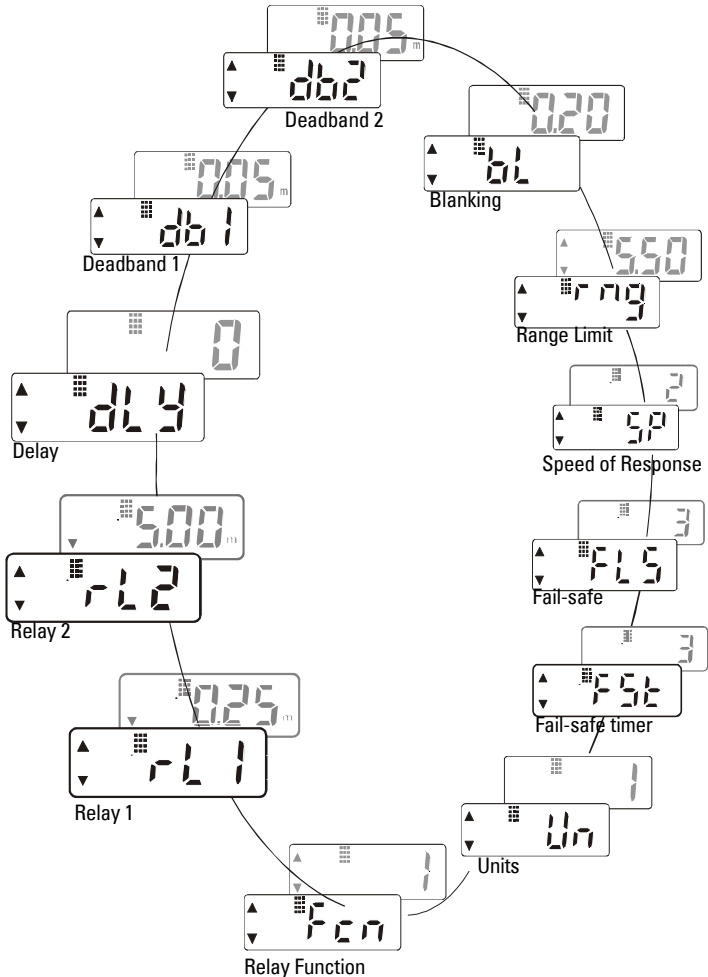

To adjust a value:



select adjustment



e.g. relay 1

current value



e.g. 0.5 m



change value



e.g. increase to 0.75 m

new value



e.g. new setpoint 0.75 m

6 s delay

return to run



For faster scrolling, hold the key depressed and release when the desired value is obtained.

Output Function



The alarms can be set to function in the desired mode.

Function	Relay 1	Relay 2
1 *	high alarm	low alarm
2	high alarm	high alarm
3	low alarm	low alarm
4	high alarm	LOE alarm
5	low alarm	LOE alarm
6	pump down	low alarm
7	pump down	high alarm
8	pump up	low alarm
9	pump up	high alarm
10	pump down	LOE alarm
11	pump up	LOE alarm
12	pump down	pump up
13	pump down	pump down
14	pump up	pump up

* Factory setting

Function display:

high alarm	H
high-high alarm	HH
low alarm	L
low-low alarm	LL
loss of echo alarm	LOE
pump up control	PU
pump down control	PD

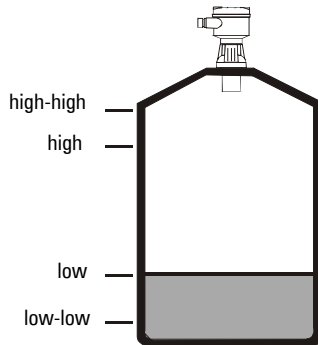

Setpoints



The setpoints can be set where reference levels, either from the material in the vessel or from a target, cannot be provided. This method can also be used to trim the output levels obtained by the Reference Method (Quick Start).

The setpoints are referenced from the face of the sensor. They should not be set at or above the blanking value, or at or below the range limit.

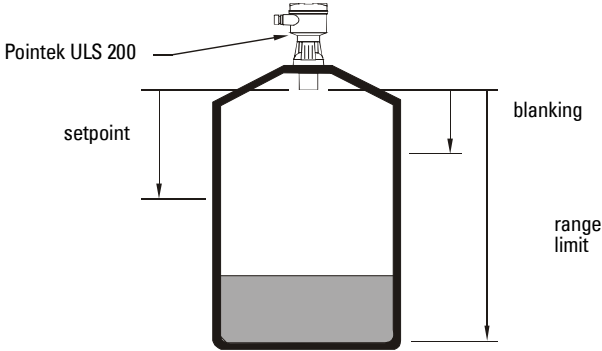

Factory Setting: Relay 1 = 0.5 m (1.64 ft)
Relay 2 = 4.50 m (14.76 ft)

Relay Delay



Adjust the time delay, in seconds, from when the material reaches the relay level and the relay is actuated. If the material level withdraws from the setpoint level, the delay is reset to 0.

The set time delay applies to both relays and all functions except 'Loss OF Echo'.

Factory setting: 0 seconds.

Relay Deadband (Reset)

Deadband (sometimes referred to as hysteresis) prevents relay chatter due to material level fluctuations at the set point. These fluctuations are often waves or turbulence on a fluid's surface caused by agitators in the tank.

Once a relay is tripped the detection level must move beyond the deadband value before it is reset. The direction in which the deadband is measured depends on the application of the relay. If the relay is for a high state then the deadband is measured below the set point. If the relay is for a low state then the deadband is measured above the set point. Refer to the diagram below.

Deadband 1 is used for Relay 1 and Deadband 2 is used for Relay 2.

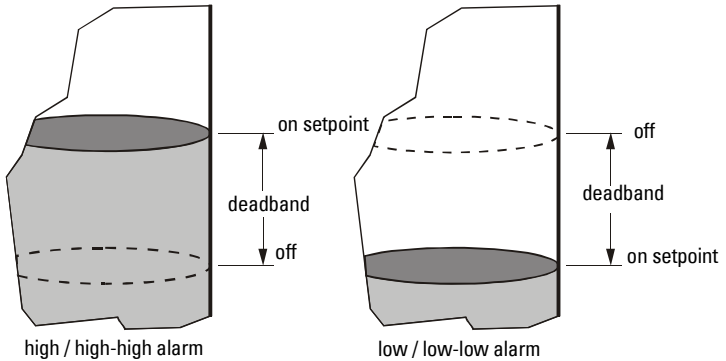

The deadband value is entered in the units selected, and applies to both relays and all alarm or control functions except 'Loss Of Echo'.

Factory setting: 0.05 m (0.16 ft)

Blanking



Blanking is used to ignore the zone in front of the transducer where false echoes are at a level that interfere with the processing of the true echo. It is measured outward from the sensor face. The minimum recommended blanking value is 0.25 m (0.82 ft) but can be increased in order to extend the blanking.

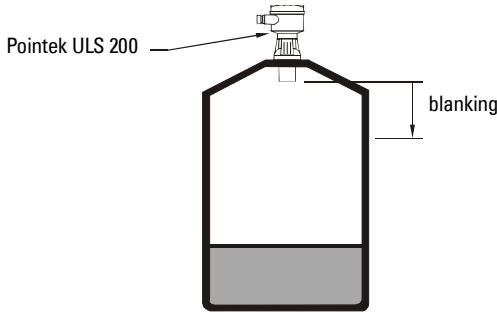

Factory setting: 0.20 m (0.66 ft)

Range Limit



The range limit is the distance at which measurements are ignored. Generally this refers to the bottom of the container being measured. If a measurement is detected beyond the range limit it results in a Loss Of Echo (LOE) reading. The result of this reading is determined by the Fail-Safe Mode, see page 25 for more information.

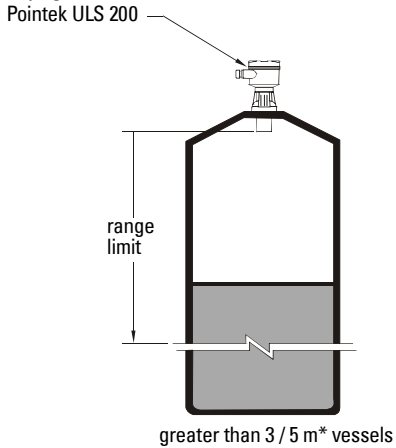
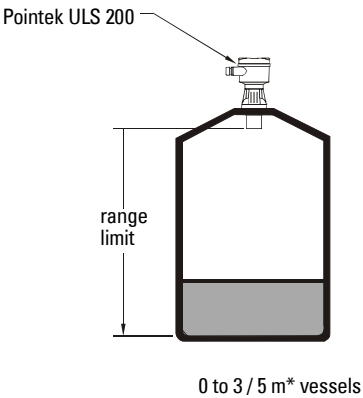

Factory setting: 5.50 m (18.0 ft)

* solids range 3 m maximum
liquids range 5 m maximum

Speed of Response

The speed of response adjustment allows the user to collectively set a number of operating parameters.

measurement response: is the limit to which the Pointek ULS 200 is able to keep up with rates of change.

If the Pointek ULS 200 measurement cannot keep up with the rate of level change, set the adjustment from `1' to `2'. If the Pointek ULS 200 still cannot keep up with the rate of level change, set the adjustment option to `3'. Avoid choosing an option that is too fast for your application.

agitator discrimination: discriminates between agitator blades in motion and the material (target) surface.

filter: discriminates between false echoes from acoustical and electrical noise and the material (target) surface.

fail-safe timer: establishes the `Waiting' period from the time a loss of echo or operating fault condition starts until the fail-safe default is effected.

SP	measurement response	agitator discrimination	filter	FLS timer
1	0.3 m / min (0.1 ft / min)	on	on	10 min
2*	1 m / min (3.3. ft / min)	on	on	10 min
3	5 m / min (16.4 ft / min)	on	on	3 min
4	immediate	off	off	3 min

* Factory setting

Fail-Safe Mode



In the event that a loss of echo condition exceeds the fail-safe timer (speed of response variable), '?' appears in the display; and if a relay is assigned to 'LOE' (alarm function option), it is engaged. This function must be used with the Output Function on page 22.

fail-safe	mode	function		reading
		high and high-high	low and low-low	
1	high	on	off	hold
2	low	off	on	hold
3*	hold	hold	hold	hold

* Factory setting

Fail-Safe Timer



The fail-safe timer allows the user to vary the waiting period from the time of a loss of echo or operating fault condition begins, until the fail-safe default is effected. The waiting period is adjustable from 1 to 15 minutes, in 1 minute increments.

Note: The fail-safe timer will default to settings determined by the speed of response (see page 26). If a different value is desired, the fail-safe timer should be adjusted after the speed of response is set.

Units



The units of the measurement reading can be selected as follows:

1 = metres, m (Factory setting)

2 = feet, ft

The selected units are also applicable to the 'Blanking' and 'Relay' adjustments.

Troubleshooting



The echo is not reliable and Pointek ULS 200 is waiting for a valid echo before updating the measurement.

Probable causes are:	Remedy
material or object in contact with sensor face	lower material level or raise Pointek ULS 200
Pointek ULS 200 is not perpendicular to the material surface	check Pointek ULS 200 mounting if angle of repose is too steep, angle Pointek ULS 200 mounting
change in level too fast	adjust speed of response
material out of range	acceptable on some high level switch applications
foam on liquid surface	mount Pointek ULS 200 via stilling well or pipe
too much dust or interference from material filling	relocate Pointek ULS 200
high level of vibration in the mounting structure	relocate Pointek ULS 200 or limit vibration
material inside blanking zone or below range limit	adjust blanking or range limit



Fail-safe default after prolonged Loss Of Echo.
Investigate the probable causes listed above.

Maintenance

The Pointek ULS 200 requires no maintenance or cleaning.

Certifications

The following instructions apply to equipment covered by certificate number SIRA 00ATEX1205:

1. The equipment may be used with flammable gases and vapours with apparatus group IIC and temperature class T5.
2. The equipment is certified for use in an ambient temperature range of -20 to 60°C (-4 to 140°C).
3. The equipment has not been assessed as a safety related device (as referred to by Directive 94/9/EC Annex II, clause 1.5).
4. Installation and inspection of this equipment shall be carried out by suitably trained personnel in accordance with the applicable code of practice (EN 60079-14 and EN 60079-17 in Europe).
5. Repair of this equipment shall be carried out by suitably trained personnel in accordance with the applicable code of practice (e.g. EN 60079-19 within Europe).
6. Components to be incorporated into or used as replacements in the equipment shall be fitted by suitably trained personnel in accordance with the manufacturer's documentation.
7. The certification of this equipment relies upon the following materials used in its construction:

Aluminum alloy T356 T6 (main enclosure) and A356 T6 (lid)
GE Lexan 943A polycarbonate
Two-part epoxy encapsulant
Silicon based coating
Santophrene 111-55 gasket
Polysulphide encapsulant (transducer)
Dupont Tefzel 210 (transducer)
Epoxy syntactic foam (transducer)

If the equipment is likely to come in contact with aggressive substances, then it is the responsibility of the user to take suitable precautions that prevent it from being adversely affected, thus ensuring that the type of protection is not compromised.

Aggressive substances: e.g. acidic liquids or gases that may attack metals, or solvents that may affect polymeric materials
Suitable precautions: e.g. regular checks as part of routine inspections or establishing from the material's data sheet that it is resistant to specific chemicals.

8. Equipment Marking: The equipment marking contains at least the following information:

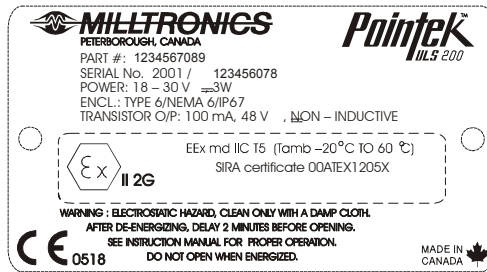
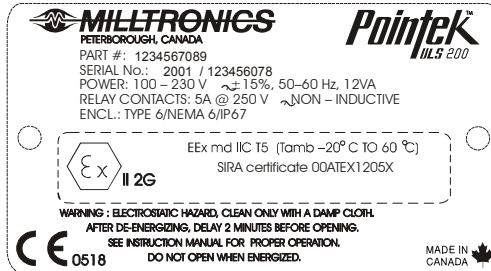
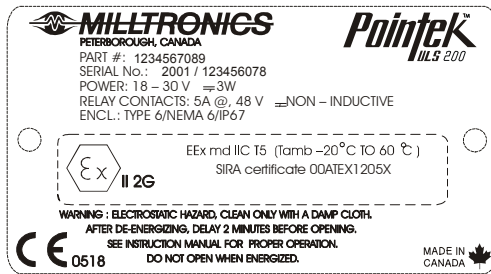

9. Special Condition for Safe Use: The apparatus must only be supplied from a circuit containing a suitable rate fuse having a breaking capacity of at least 4000 A.



www.siemens-milltronics.com

Siemens Milltronics Process Instruments Inc.
1954 Technology Drive, P.O. Box 4225
Peterborough, ON, Canada K9J 7B1
Tel: (705) 745-2431 Fax: (705) 741-0466
Email: techpubs@siemens-milltronics.com

© Siemens Milltronics Process Instruments Inc. 2003
Subject to change without prior notice



7 M L 1 9 9 8 1 A S 0 1
Printed in Canada

Rev. 1.2